



**Quick-access door, with
viewport, DN 100 CF**

PFEIFFER 

Quick-Access door, with sight glass

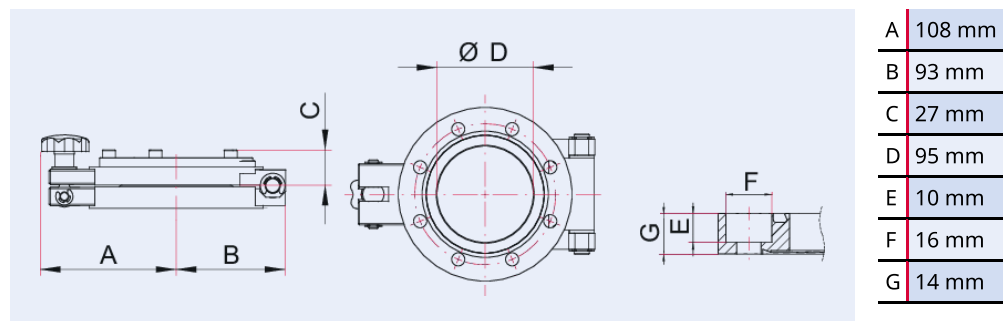

Illustration only

Quick-access door, with viewport, DN 100 CF

- Screw holes: Through-holes with counter-bore for cylinder head
- Can be installed using hexagon socket screws

Dimensions



Technical Data

Technical Data	Quick-access door, with viewport, DN 100 CF
Materials in contact with media	Stainless steel
Number of screws	16 Pieces
Seal	FKM
O-ring material	FKM
Temperature range	15 – 150 °C
Sight glass	Borosilicate glass
Connection flange	DN 100 CF
Pressure range	$1 \cdot 10^{-8}$ hPa – to ambient pressure
Temperature range max.	150 °C 302 °F 423.15 K
Temperature range min.	15 °C 59 °F 288.15 K

Order number	Quick-access door, with viewport, DN 100 CF
Quick-access door, with viewport, DN 100 CF	420KTU100-G



Errors and/or changes excepted. - 5/14/2025

Are you looking for an optimum vacuum solution?

Talk to us:

Pfeiffer Vacuum Components & Solutions GmbH Germany

T +49 551 99963-0

info-cs@pfeiffer-vacuum.com

Or scan the barcode, to visit our web page:



<https://webportal.pfeiffer-vacuum.com/global/en/contact>

Follow Us On Social Media

#pfeiffervacuum



www.pfeiffer-vacuum.com

PFEIFFER 