



# Bulkhead clamp

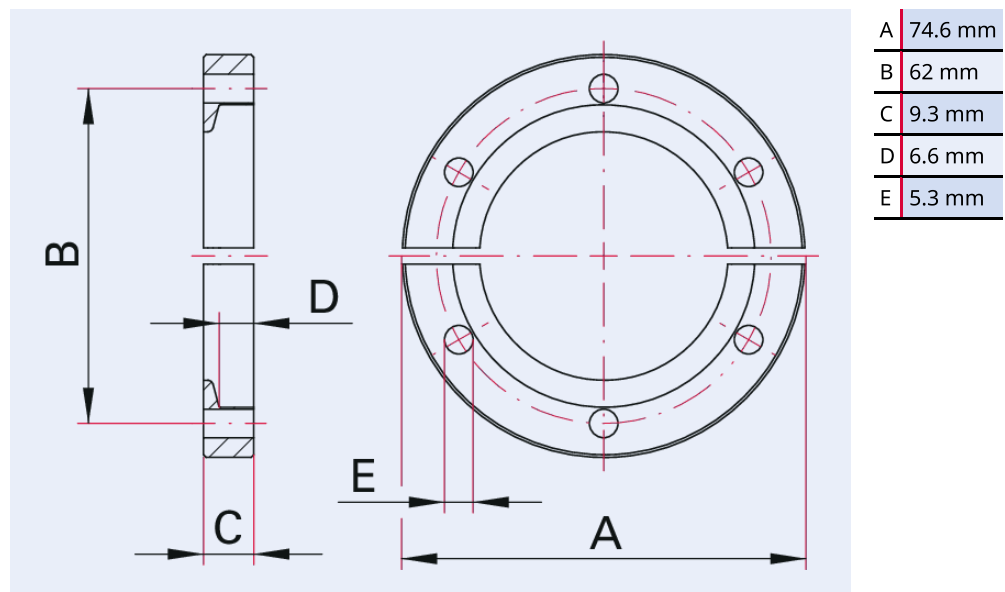

Illustration only

## Bulkhead clamp, aluminum EN AW-6082/3.2315, DN 32-40 ISO-KF

- Suitable for use with elastomer seals
- Nominal diameter DN 40 ISO-KF suitable for safe fixation of the HiPace 30
- Screws and washers included
- For mounting on a base plate with KF centering ring
- DN16, DN25, DN50 not to be used for the installation of turbo pumps! Use the fastening elements given in the corresponding operating instructions.

## Dimensions



<b>Technical Data</b>	<b>Bulkhead clamp, aluminum EN AW-6082/3.2315, DN 32-40 ISO-KF</b>
Number of screws	6 Pieces
Over pressure max.	500 hPa
Holes	Number of tapped holes in base plate: DN 10-40: 6 x 60°; DN 50: 8 x 45° (Thread M5, depth: min. 10 mm)
Temperature range	196 – 200 °C
Scope of delivery	Bulkhead Clamp   6 hexagon screws M5x20 with washers
Overpressure max.	500 hPa   375 Torr   500 mbar
Connection flange	DN 32 – DN 40 ISO-KF
Material	Aluminum 3.2315/EN AW-6082
Temperature range max.	200 °C   392 °F   473.15 K
Temperature range min.	196 °C   320.8 °F   77.15 K

<b>Order number</b>	<b>Bulkhead clamp, aluminum EN AW-6082/3.2315, DN 32-40 ISO-KF</b>
Bulkhead clamp, aluminum EN AW-6082/3.2315, DN 32-40 ISO-KF	110BUH040



Errors and/or changes excepted. - 5/14/2025

Are you looking for an optimum vacuum solution?

Talk to us:

**Pfeiffer Vacuum Components & Solutions GmbH Germany**

**T +49 551 99963-0**

**info-cs@pfeiffer-vacuum.com**

Or scan the barcode, to visit our web page:



<https://webportal.pfeiffer-vacuum.com/global/en/contact>

Follow Us On Social Media

#pfeiffervacuum



[www.pfeiffer-vacuum.com](http://www.pfeiffer-vacuum.com)

**PFEIFFER** 