



**Welding flange, with
imperial thread,
stainless steel 304L,
DN 50 CF**



PFEIFFER 

Welding flange



Illustration only

Welding flange, with imperial thread, stainless steel 304L, DN 50 CF

Dimensions

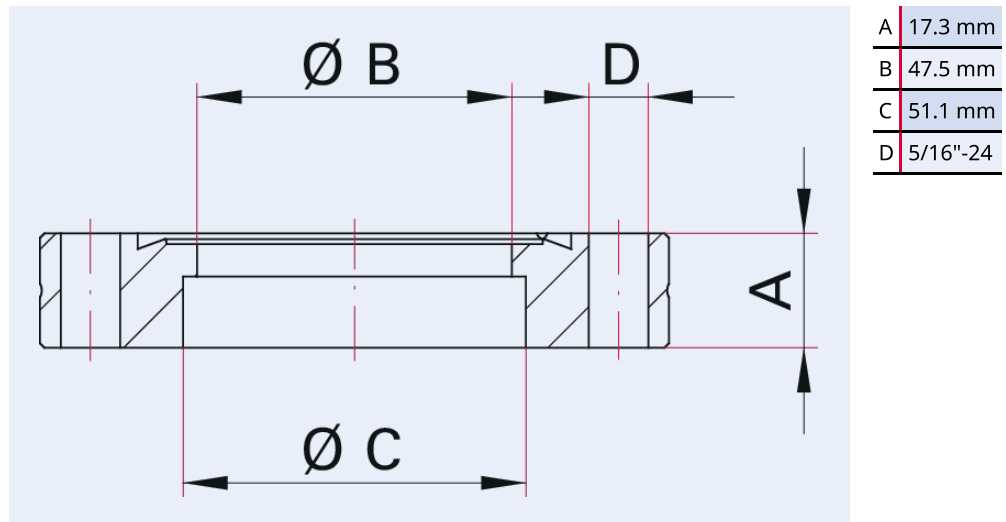

Technical Data	Welding flange, with imperial thread, stainless steel 304L, DN 50 CF
Materials in contact with media	Stainless steel (AISI 304L)
Number of screws	8 Pieces
Pipe dimension	50.8 mm × 1.65 mm
Thread	5/16" - 24 UNF
Temperature range	196 – 300 °C
Connection flange	DN 50 CF
Pressure range	1 · 10 ⁻¹² hPa – to ambient pressure
Temperature range max.	300 °C 572 °F 573.15 K
Temperature range min.	196 °C 320.8 °F 77.15 K

Order number	Welding flange, with imperial thread, stainless steel 304L, DN 50 CF
Welding flange, with imperial thread, stainless steel 304L, DN 50 CF	420FAN050-50-T



Errors and/or changes excepted. - 5/14/2025

Are you looking for an optimum vacuum solution?
Talk to us:
Pfeiffer Vacuum Components & Solutions GmbH Germany
T +49 551 99963-0
info-cs@pfeiffer-vacuum.com

Or scan the barcode, to visit our web page:



<https://webportal.pfeiffer-vacuum.com/global/en/contact>

Follow Us On Social Media
#pfeiffervacuum



www.pfeiffer-vacuum.com

PFEIFFER 