



OPERATING INSTRUCTIONS

EN

Original

MANUAL GATE VALVE

Valve

Dear customer,

Thank you for choosing a Pfeiffer Vacuum product. Your new Pfeiffer Vacuum valves should support you in your individual application with full performance and without malfunctions. The name Pfeiffer Vacuum stands for high-quality vacuum technology, a comprehensive and complete range of top-quality products and first-class service. With this expertise, we have acquired a multitude of skills contributing to an efficient and secure implementation of our product.

Knowing that our product must not interfere with your actual work, we are convinced that our product offers you the solution that supports you in the effective and trouble-free execution of your individual application.

Please read these operating instructions before putting your product into operation for the first time. If you have any questions or suggestions, please feel free to contact info@pfeiffer-vacuum.de.

Further operating instructions from Pfeiffer Vacuum can be found in the [Download Center](#) on our website.

Disclaimer of liability

These operating instructions describe all models and variants of your product. Note that your product may not be equipped with all features described in this document. Pfeiffer Vacuum constantly adapts its products to the latest state of the art without prior notice. Please take into account that online operating instructions can deviate from the printed operating instructions supplied with your product.

Furthermore, Pfeiffer Vacuum assumes no responsibility or liability for damage resulting from the use of the product that contradicts its proper use or is explicitly defined as foreseeable misuse.

Copyright

This document is the intellectual property of Pfeiffer Vacuum and all contents of this document are protected by copyright. They may not be copied, altered, reproduced or published without the prior written permission of Pfeiffer Vacuum.

We reserve the right to make changes to the technical data and information in this document.

Table of contents

1	About this manual	5
1.1	Validity	5
1.1.1	Products concerned	5
1.2	Target group	5
1.3	Conventions	5
1.3.1	Instructions in the text	5
1.3.2	Pictographs	5
1.3.3	Abbreviations	6
1.4	Trademark proof	6
2	Safety	7
2.1	General safety information	7
2.2	Safety instructions	7
2.3	Safety precautions	8
2.4	Limits of use of the product	8
2.5	Proper use	9
2.6	Foreseeable misuse	9
2.7	Personnel qualification	9
2.7.1	Ensuring personnel qualification	9
2.7.2	Personnel qualification for maintenance and repair	10
2.7.3	Advanced training with Pfeiffer Vacuum	10
3	Product description	11
3.1	Function	11
3.2	Scope of delivery	11
3.3	Identifying the product	11
3.3.1	Product types	12
3.3.2	Product features	12
4	Transportation and Storage	13
4.1	Transport	13
4.2	Storage	13
5	Installation	14
5.1	Preparatory work	14
5.2	Bench test	14
5.3	Mounting orientation	14
5.4	Mounting instructions	15
5.4.1	Torque values	15
5.4.2	Proper torque sequence	15
6	Operation	17
7	Maintenance	18
7.1	General maintenance information	18
7.2	Removing bonnet actuator carriage assembly	19
7.3	Maintaining gate and bonnet seals	19
7.4	Actuator bearings lubrication & adjustment	20
7.5	Replace bellows and shaft seals	23
7.6	Cleaning seal plate assembly, pins, and bearings	25
7.7	Valve adjustment	27
8	Decommissioning	29
9	Recycling and disposal	30
9.1	General disposal information	30
10	Malfunctions	31

11	Service solutions by Pfeiffer Vacuum	32
12	Spare parts - Gate valve	34
13	Technical data and dimensions	35
	13.1 General	35
	13.2 Technical data and product dimensions	35

1 About this manual



IMPORTANT

Read carefully before use.
Keep the manual for future consultation.

1.1 Validity

This operating instructions is a customer document of Pfeiffer Vacuum. The operating instructions describe the functions of the named product and provide the most important information for the safe use of the device. The description is written in accordance with the valid directives. The information in this operating instructions refers to the product's current development status. The document shall remain valid provided that the customer does not make any changes to the product.

1.1.1 Products concerned

This document applies to products with the following part numbers:

Part number	Description
GV-Sxxxxxx	Models for high vacuum applications
GVM-Sxxxxxx	Models for ultra high vacuum applications

1.2 Target group

These operating instructions are aimed at all persons performing the following activities on the product:

- Transportation
- Setup (Installation)
- Usage and operation
- Decommissioning
- Maintenance and cleaning
- Storage or disposal

The work described in this document is only permitted to be performed by persons with the appropriate technical qualifications (expert personnel) or who have received the relevant training from Pfeiffer Vacuum.

1.3 Conventions

1.3.1 Instructions in the text

Usage instructions in the document follow a general structure that is complete in itself. The required action is indicated by an individual step or multi-part action steps.

Individual action step

A horizontal, solid triangle indicates the only step in an action.

- ▶ This is an individual action step.

Sequence of multi-part action steps

The numerical list indicates an action with multiple necessary steps.

1. Step 1
2. Step 2
3. ...

1.3.2 Pictographs

Pictographs used in the document indicate useful information.



Note



Tip

1.3.3 Abbreviations

Abbreviation	Meaning in this document
CDA	Clean dry air
CF	Flange: Metal-sealed connector in accordance with ISO 3669
Delta P	Delta pressure
DN	Nominal diameter as size description
FKM	Fluoropolymer rubber
GV	Manual gate valve, HV
GVM	Manual gate valve, UHV
HV	High vacuum
IPA	Isopropyl alcohol
ISO	Flange: Connection in accordance with ISO 1609 and ISO 2861
OFHC	Oxygen free copper
UHV	Ultra-high vacuum

Tbl. 1: Abbreviations used in this document

1.4 Trademark proof

- Apiezon® is a trademark of M&I Materials Ltd.
- Allen® is a trademark of Apex Brands, Inc
- Castrol™ is a trademark of Castrol Ltd. UK
- Loctite® is a trademark of Henkel IP & Holding GmbH, Germany.

2 Safety

2.1 General safety information

The following 4 risk levels and 1 information level are taken into account in this document.

DANGER

Immediately pending danger

Indicates an immediately pending danger that will result in death or serious injury if not observed.

- ▶ Instructions to avoid the danger situation

WARNING

Potential pending danger

Indicates a pending danger that could result in death or serious injury if not observed.

- ▶ Instructions to avoid the danger situation

CAUTION

Potential pending danger

Indicates a pending danger that could result in minor injuries if not observed.

- ▶ Instructions to avoid the danger situation

NOTICE

Danger of damage to property

Is used to highlight actions that are not associated with personal injury.

- ▶ Instructions to avoid damage to property



Notes, tips or examples indicate important information about the product or about this document.

2.2 Safety instructions

Risks during transport

WARNING

Danger of serious injury due to falling objects

Due to falling objects there is a risk of injuries to limbs through to broken bones.

- ▶ Take particular care and pay special attention when transporting products manually.
- ▶ Do not stack the products.
- ▶ Wear protective equipment, e.g. safety shoes.

Risks during installation

WARNING

Risk of injury due to incorrect installation

Dangerous situations may arise from unsafe or incorrect handling

- ▶ Do not put hands or any other body part or objects in the valve.

Risks during maintenance, decommissioning and disposal

⚠ WARNING

Health hazard through poisoning from toxic contaminated components or devices

Toxic process media result in contamination of devices or parts of them. During maintenance work, there is a risk to health from contact with these poisonous substances. Illegal disposal of toxic substances causes environmental damage.

- ▶ Take suitable safety precautions and prevent health hazards or environmental pollution by toxic process media.
- ▶ Decontaminate affected parts before carrying out maintenance work.
- ▶ Wear protective equipment.

2.3 Safety precautions

i **Duty to provide information on potential dangers**

The product holder or user is obliged to make all operating personnel aware of dangers posed by this product.

Every person who is involved in the installation, operation or maintenance of the product must read, understand and adhere to the safety-related parts of this document.

i **Infringement of conformity due to modifications to the product**

The Declaration of Conformity from the manufacturer is no longer valid if the operator changes the original product or installs additional equipment.

- Following the installation into a system, the operator is required to check and re-evaluate the conformity of the overall system in the context of the relevant European Directives, before commissioning that system.

General safety precautions when handling the product

- ▶ Observe all applicable safety and accident prevention regulations.
- ▶ Check that all safety measures are observed at regular intervals.
- ▶ Never put hands or any other object in the valve.

2.4 Limits of use of the product

Parameter	Limit value
Installation orientation	Product may be installed in any orientation, with flow in either direction. Common installation direction is gate seal side facing away from the vacuum pump
Allowable ambient humidity	0 - 95 % non-condensing
Process temperature range	-18 °C - 200 °C Process temperatures above 150 °C may require use of seal materials other than FKM
Heating capabilities	Body can be heated up to 150 °C Actuator can be heated up to 60 °C
Maximum internal pressure	1400 hPa
Maximum delta P before opening	30 hPa in open direction. 30 hPa in closing direction.
Reliability	100,000 cycles in a clean environment
Leak rate	High Vacuum: 1 x 10 ⁻⁹ hPa l/s Ultra-High Vacuum: 1 x 10 ⁻¹⁰ hPa l/s

Tbl. 2: Limits of use for manual gate valves

2.5 Proper use

- ▶ Use the valve to isolate vacuum.
- ▶ Use the valve only in closed indoor areas.
- ▶ Use the valve only for the evacuation of dry and inert gases.

2.6 Foreseeable misuse

Improper use of the product invalidates all warranty and liability claims. Any use that is counter to the purpose of the product, whether intentional or unintentional, is regarded as misuse, in particular:

- Use outside the mechanical and electrical application limits in accordance with the technical data
- Use with corrosive or explosive media, if this is not explicitly permitted
- Use outdoors
- Use with bare hands or with powder gloves
- Use after unauthorized technical changes (on the inside or the outside of the product)
- Use with replacement or accessory parts that are unsuitable or are not approved

2.7 Personnel qualification

The work described in this document may only be carried out by persons who have appropriate professional qualifications and the necessary experience or who have completed the necessary training as provided by Pfeiffer Vacuum.

Training people

1. Train the technical personnel on the product.
2. Only let personnel to be trained work with and on the product when under the supervision of trained personnel.
3. Only allow trained technical personnel to work with the product.
4. Before starting work, make sure that the commissioned personnel have read and understood these operating instructions and all applicable documents, in particular the safety, maintenance and repair information.

2.7.1 Ensuring personnel qualification

Specialist for mechanical work

Only a trained specialist may carry out mechanical work. Within the meaning of this document, specialists are people responsible for construction, mechanical installation, troubleshooting and maintenance of the product, and who have the following qualifications:

- Qualification in the mechanical field in accordance with nationally applicable regulations
- Knowledge of this documentation

Specialist for electrotechnical work

Only a trained electrician may carry out electrical engineering work. Within the meaning of this document, electricians are people responsible for electrical installation, commissioning, troubleshooting, and maintenance of the product, and who have the following qualifications:

- Qualification in the electrical engineering field in accordance with nationally applicable regulations
- Knowledge of this documentation

In addition, these individuals must be familiar with applicable safety regulations and laws, as well as the other standards, guidelines, and laws referred to in this documentation. The above individuals must have an explicitly granted operational authorization to commission, program, configure, mark, and earth devices, systems, and circuits in accordance with safety technology standards.

Trained individuals

Only adequately trained individuals may carry out all works in other transport, storage, operation and disposal fields. Such training must ensure that individuals are capable of carrying out the required activities and work steps safely and properly.

2.7.2 Personnel qualification for maintenance and repair



Advanced training courses

Pfeiffer Vacuum offers advanced training courses to maintenance levels 2 and 3.

Adequately trained individuals are:

- **Maintenance level 1**
 - Customer (trained specialist)
- **Maintenance level 2**
 - Customer with technical education
 - Pfeiffer Vacuum service technician
- **Maintenance level 3**
 - Customer with Pfeiffer Vacuum service training
 - Pfeiffer Vacuum service technician

2.7.3 Advanced training with Pfeiffer Vacuum

For optimal and trouble-free use of this product, Pfeiffer Vacuum offers a comprehensive range of courses and technical trainings.

For more information, please contact [Pfeiffer Vacuum technical training](#).

3 Product description

3.1 Function

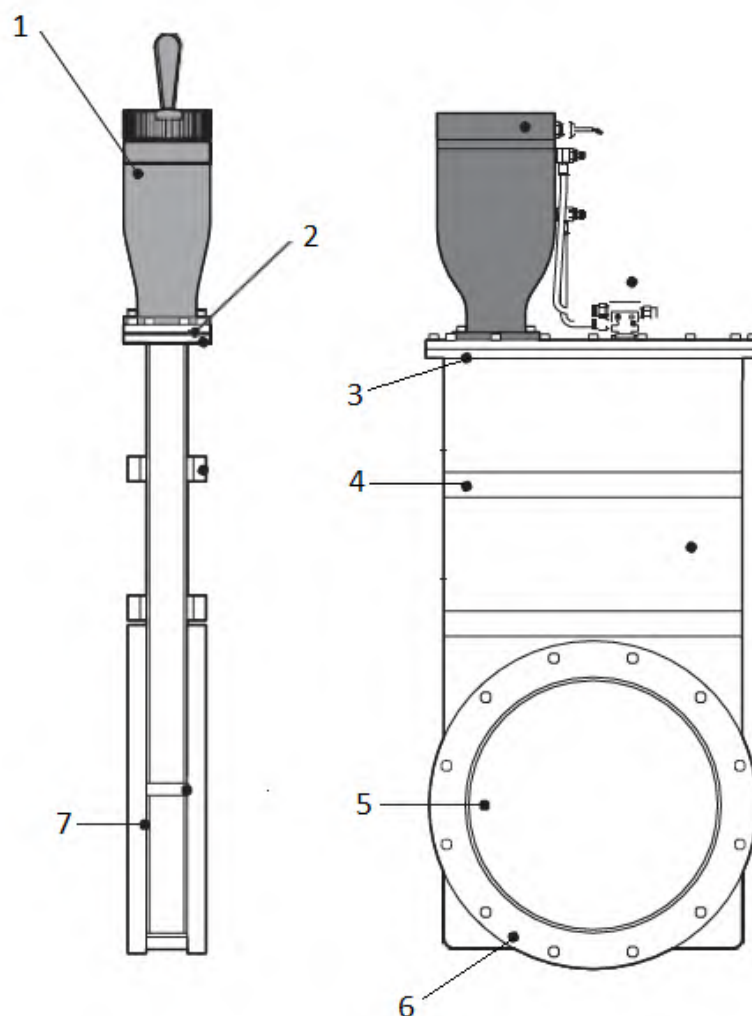

Fig. 1: Manual gate valve overview

- | | |
|--|--------------------------------------|
| 1 Manual actuator: crank handle for DN 80 and larger | 5 Gate (seal) side with O-ring |
| 2 Bonnet seal: elastomer or metal | 6 Port flange: standard CF or KF/ISO |
| 3 Bonnet flange | 7 Carriage side |
| 4 Structural supports | |

The manual gate valve features a positive lock-over center mechanism. Easy access to all serviceable parts makes maintenance quick and effortless.

3.2 Scope of delivery

- Valve
- Quick-start guide

3.3 Identifying the product

- ▶ To ensure clear identification of the product when communicating with Pfeiffer Vacuum, always keep all of the information on the model number and serial number on hand.

3.3.1 Product types

The product designation of Pfeiffer Vacuum gate valves from the GV (high vacuum) and GVM (ultra-high vacuum) series is composed of the family name, the size and, if required, an additional feature description.

Family	Size/model
GV	DN 16 to 320
GVM	DN 16 to 320

Tbl. 3: Product designation of Pfeiffer Vacuum manual gate valves

3.3.2 Product features

Feature	Description	Valve Version
Valve body material	304 stainless steel	GV and GVM
Welded bellows shaft seal	AM-350	GV and GVM
Bonnet / gate seals	FKM elastomer	GV
	OFHC copper / FKM elastomer	GVM

Tbl. 4: Manual gate valve features

4 Transportation and Storage

4.1 Transport

WARNING

Danger of serious injury due to falling objects

Due to falling objects there is a risk of injuries to limbs through to broken bones.

- ▶ Take particular care and pay special attention when transporting products manually.
- ▶ Do not stack the products.
- ▶ Wear protective equipment, e.g. safety shoes.



We recommend

Pfeiffer Vacuum recommends keeping the transport packaging and original protective cover.

Instructions for safe transport

- ▶ Transport the valve only within the permissible temperature limits.
- ▶ Where possible, always transport or ship the valve in its original packaging.
- ▶ Always carry the valve with both hands or use adequate equipment to transport the valve.
- ▶ Remove the protective cover only immediately prior to installation.
- ▶ Transport the valve in the closed position.

4.2 Storage



We recommend

Pfeiffer Vacuum recommends storing the products in their original transport packaging.

Storing the valve

1. Seal all flange openings with the original protective caps.
2. Seal all other connections (e.g. venting connection) with the corresponding original parts.
3. Store the valve only indoors within the permissible temperature limits.

5 Installation

5.1 Preparatory work

⚠ WARNING
Risk of injury due to incorrect installation Dangerous situations may arise from unsafe or incorrect handling <ul style="list-style-type: none"> ▶ Do not put hands or any other body part or objects in the valve.

General notes for the installation of vacuum components

- ▶ Choose an installation location that permits access to the product and to supply lines at all times.
- ▶ Observe the ambient conditions given for the limits of use.
- ▶ Provide the highest possible level of cleanliness during assembly.
- ▶ Ensure that flange components during installation are grease-free, dust-free and dry.

Required tools and materials

- Lint-free, dry wipe
- Powder-free latex gloves
- Vacuum grease

Pre-installation

1. Observe the instructions for transport to the installation location.
2. Determine that the valve and adjacent plumbing in the vacuum system will be adequately supported when installed.
3. Make sure the mating flanges are in line, flat, parallel, and the correct distance apart to minimize straining of the valve body.
4. Remove the flange cover and wipe the flange and gaskets with a lint-free, dry wipe.
5. If installing an o-ring seal flange, apply a light film of vacuum grease to the o-ring and install in the flange groove.

5.2 Bench test

A capacitance manometer is not necessary for test purposes. If possible, test the unit when it is under vacuum.

Prerequisites

- Before installing the valve into a system, run a bench test to verify the gate functions are operational.

Bench test procedure

1. Confirm that the valve actuates properly by carefully checking the operation of the valve using the minimum torque on the actuator to achieve full closure.
2. From the open position, slowly close the valve by turning the actuator until you visually see the gate O-ring make contact.
 - Turn the actuator clockwise when looking down on the actuator to close the valve. Turn the actuator counter-clockwise to open the valve.
3. Increase closing torque as necessary to hear and feel the gate lock into its closed position.
 - Once the gate has been locked closed, no additional torque on the actuator will improve the gate seal.
4. The weight of the carriage assembly, especially in larger valves, may cause the drive screw mechanism to “chatter” when the valve is being opened or closed. This is normal and, when operating within recommended parameters, does not cause damage to the valve.

5.3 Mounting orientation



It is preferable to install the valve with vacuum on the backside of the gate so the valve body remains under vacuum at all times and the pump down of the valve body is eliminated.

- For sizes 16 mm – 160 mm, valve can be mounted in any orientation
- For sizes 200 mm – 320 mm and greater, contact Pfeiffer Vacuum Service for suggested valve orientation.
- Valves are adjusted for horizontal actuation.
- Valves that are mounted with vertical actuation may require more torque on the actuator knob to compensate for the weight of the gate-carriage assembly.

5.4 Mounting instructions

- ▶ Make sure no foreign particles enter the valve.
- ▶ When installing the valve, it is imperative that proper length bolts be used.
 - Bolts longer than the thickness of both mating flanges will damage the body panels and destroy the seal surface area for the gate O-ring.
 - For best results, always use bolts that are at least 1/4-inch (6.4 mm) shorter than the thickness of both mating flanges.
- ▶ Lightly grease the flange bolts with high temperature, non-galling type grease such as Loctite® Heavy Duty Anti-Seize or equivalent.
- ▶ Carefully tighten the bolts around the flange using the proper torque sequence until flanges are metal to metal and bolts are at proper torque.

5.4.1 Torque values

Valve size (mm)	Torque (Nm)
16	8.2 - 10.9
40	16.3 - 17.7
50 and larger	16.3 - 20.4

Tbl. 5: Torque values for copper gaskets for CF-F flanges

Valve size (mm)	Torque (Nm)
16	2.7 - 4.1
40	4.1 - 5.4
50 and larger	4.1 - 8.2

Tbl. 6: Torque values for FKM O-rings for ISO and other flanges

5.4.2 Proper torque sequence

Prerequisites

- 180° bolt sequence.
- Always follow the proper bolt sequence for each of the following steps of tightening.

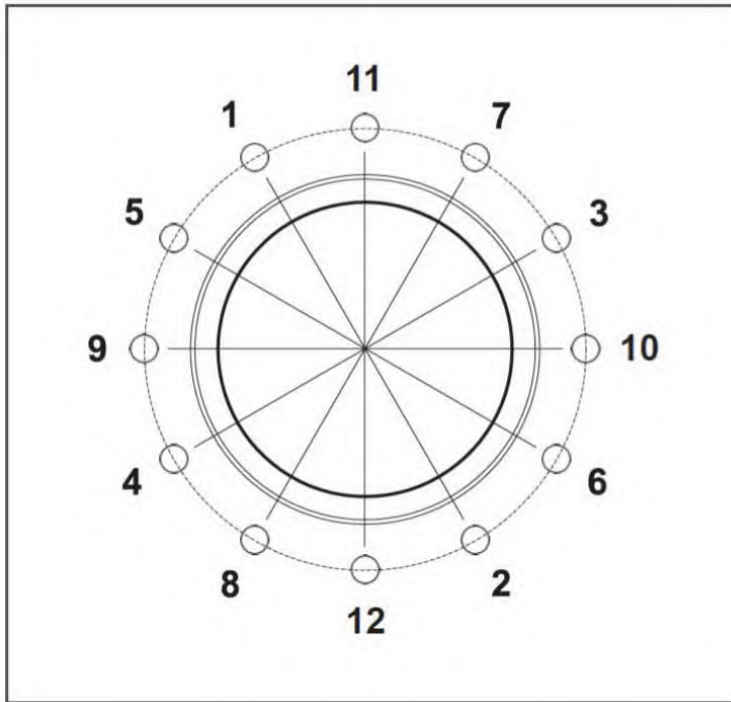

Fig. 2: Torque sequence example

Number of bolt holes will vary depending on flange type and size.

Proper tightening

1. Finger tighten bolts first.
2. Tighten supply with wrench to 1/2 the required torque.
3. Tighten to recommended torque range.

6 Operation

- For continued trouble-free operation, keep the valve clean and free of contaminants.
- Use powder-free latex gloves to avoid contaminating the valve with finger oils.
- Work in a clean environment to avoid other contamination.
- Use the crank handle to manually open or close the gate valve.

7 Maintenance

7.1 General maintenance information

⚠ WARNING

Health hazard through poisoning from toxic contaminated components or devices

Toxic process media result in contamination of devices or parts of them. During maintenance work, there is a risk to health from contact with these poisonous substances. Illegal disposal of toxic substances causes environmental damage.

- ▶ Take suitable safety precautions and prevent health hazards or environmental pollution by toxic process media.
- ▶ Decontaminate affected parts before carrying out maintenance work.
- ▶ Wear protective equipment.

General notes

- For continued trouble-free operation, keep the valve clean and free of contaminants.
- Use powder-free latex gloves to avoid contaminating the valve with finger oils.
- Work in a clean environment to avoid other contamination.
- Use the crank handle to manually open or close the gate valve.

Required spare parts

1. To order replacement parts or repair kits, contact Pfeiffer Vacuum service.
2. Please provide the model number and serial number when ordering replacement parts.

Serviceable parts

- ▶ Contact Pfeiffer Vacuum service for repair of non-user-serviceable parts

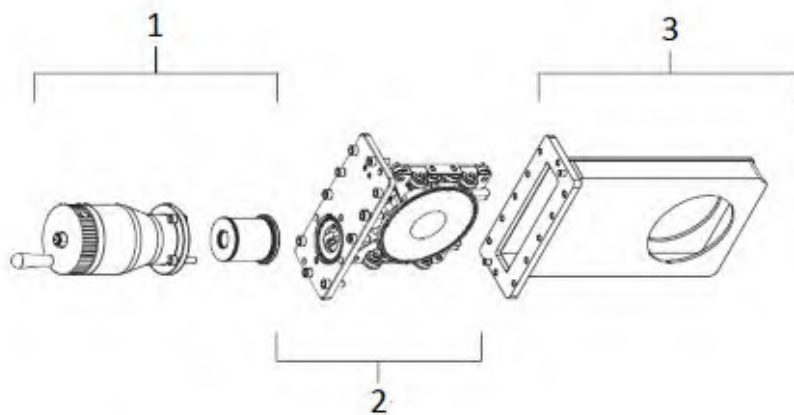

Fig. 3: Manual gate valve | serviceability

- | | |
|-------------------|--------------|
| 1 Gate actuator | 3 Valve body |
| 2 Gate/strongback | |

Gate actuator	Gate/strongback	Valve body
<ul style="list-style-type: none"> • Thrust & radial bearings • Drive shaft O-ring • Bellows¹⁾ • Bellows O-ring²⁾ 	<ul style="list-style-type: none"> • Gate O-ring • Bonnet O-ring or gasket • Pins • Bearings • Washers • Retaining rings • Set screws • Gate spring 	<ul style="list-style-type: none"> • No user-serviceable parts

Tbl. 7: Manual gate valve | serviceable parts

7.2 Removing bonnet actuator carriage assembly



- Always wear powder-free latex gloves when servicing the valve
- Be careful not to scratch o-ring groove
- Avoid twisting, stretching, or deforming the o-ring
- Avoid damaging the materials
- Heat gun may be required to melt any Loctite on jam nut threads

All servicing of O-rings, bellows, pins, and bearings requires removal of the bonnet actuator carriage assembly from the valve body.

Required tools and materials

- Allen wrench set: sizes 0.028" - 3/8"
- 1/2" box wrench
- 1/4" 12pt. wrench
- 5/16" 12pt. wrench
- Powder-free latex gloves
- Appropriate replacement O-rings or metal gasket

Prerequisites

- Vacuum system vented to atmospheric pressure
- Electrical supply disconnected
- Valve actuated to GATE OPEN position

Procedure

1. Remove the bolts that hold the bonnet actuator carriage assembly to the body.
2. Pull out the bonnet actuator carriage assembly, taking care not to move the adjustment of the linkage.
3. Support the carriage with a block to minimize stress on linkage

7.3 Maintaining gate and bonnet seals



- Always wear powder-free latex gloves when servicing the valve
- Be careful not to scratch o-ring groove
- Avoid twisting, stretching, or deforming the o-ring
- Avoid damaging the materials
- Heat gun may be required to melt any Loctite on jam nut threads

For standard and metal seal bonnets

Required tools and materials

- Allen wrench set: sizes 0.028" - 3/8"
- 1/2" box wrench
- O-ring pick, plastic
- Powder-free latex gloves

1) For valves with elastomer sealed bonnets only

2) For valves with elastomer sealed bonnets only

- Grease for O-rings: Apiezon L
- Isopropyl alcohol
- Appropriate replacement O-rings or metal gasket

Prerequisites

- Bonnet actuator carriage assembly removed

Remove bonnet O-ring

1. Remove bonnet O-ring or metal gasket with a plastic pick to avoid scratching the O-ring groove.
2. Remove gate O-ring with the plastic pick to avoid scratching the O-ring groove.
3. Discard the O-rings or metal gaskets.
4. Clean the O-ring groove with IPA and dry out with nitrogen or CDA.
5. Apply a light coat of Apiezon-L grease to the new gate O-ring.

Insert new bonnet O-ring

1. Install new O-ring on the gate.
 - Set new O-ring on gate
 - Press O-ring in at 6 and 12 o'clock
 - Press at 3 and 9 o'clock
 - Continue pressing O-ring into groove at 180° apart intervals
 - Smooth out the O-ring all the way around the groove
2. Apply a light coat of Apiezon-L grease to the new bonnet assembly FKM O-ring. Install the copper gasket dry.
3. Install new O-ring or gasket on the bonnet assembly.
4. Replace bonnet actuator carriage assembly into the body.
5. Install bolts and tighten.
 - For metal seal/copper gasket type, tighten each bolt 1/8th turn at a time until bonnet plate and body are metal to metal.

7.4 Actuator bearings lubrication & adjustment



- Always wear powder-free latex gloves when servicing the valve
- Be careful not to scratch o-ring groove
- Avoid twisting, stretching, or deforming the o-ring
- Avoid damaging the materials
- Heat gun may be required to melt any Loctite on jam nut threads

DN 40 to DN 320 sizes only

Required tools and materials

- To do the tension adjustment correctly you will need a vice to hold the assembly
- 1 - 1/4" open ended or socket wrench
- Allen wrench set: size 0.028" - 3/8"
- Powder-free latex gloves
- Replacement bearings
- Grease for metal seal bonnet version: C-100 anti-gall high temp
- Vacuum grease
- IPA

Prerequisites

- Determine gate position based on orientation of the valve during servicing
 - If the valve is laying FLAT on a workbench or installed with the actuator to the SIDE, close the valve.
 - If the installed valve position is with the actuator UP, close the valve.
 - If the installed valve position is with the actuator DOWN, leave the valve open.

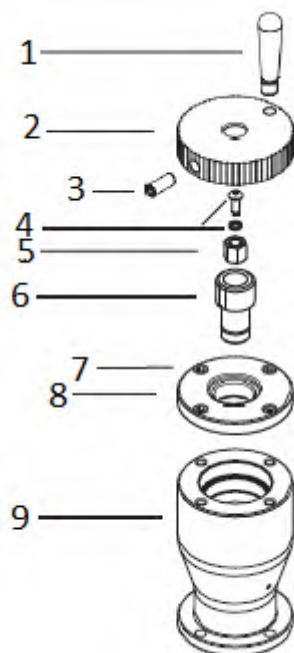

Fig. 4: Assembly of the knob and crank

- | | |
|----------------------------------|--------------------------|
| 1 Crank | 6 Drive nut |
| 2 Actuator knob | 7 Set screw, socket head |
| 3 Set screw, socket head | 8 Bearing block |
| 4 Screw (left-handed) and washer | 9 Actuator housing |
| 5 Drive screw stop | |

Remove knob and crank

1. Lay valve in flat position if possible.
2. Remove the left-hand threaded screw located on the top of the actuator.
 - This screw only has a left-handed thread and must be turned clockwise to loosen.
3. Remove the drive screw stop.
4. Loosen the set screw located on the side of the knob.
 - The set screw does not need to be completely removed.
5. Pull the knob off.
 - Notice a flat on the drive nut.

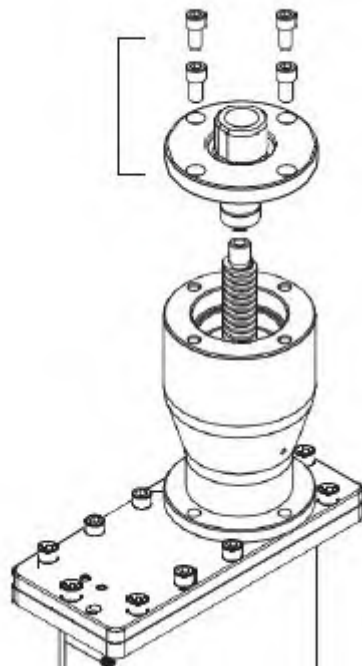

Fig. 5: Drive nut and bearing block assembly

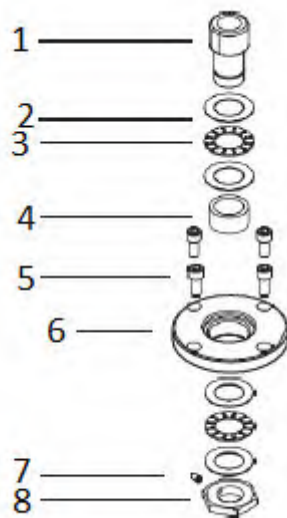

Fig. 6: Drive nut and bearing assembly: exploded view

- | | |
|------------------|----------------------|
| 1 Drive nut | 5 Screw, socket head |
| 2 Thrust washer | 6 Bearing block |
| 3 Thrust bearing | 7 Set screw |
| 4 Radial bearing | 8 Lock nut |

Disassemble drive nut and bearing block

1. Remove the bearing block screws (4 each) located above the bearing block.
2. Remove the bearing block assembly by turning clockwise.
 - The ACME thread on the actuator stem is left-handed.
3. Loosen the set screw on the brass hex nut.
 - The set screw does not have to be completely removed.
4. Remove nut on DN 100 to DN 320 gate valves / Remove retaining ring on DN 40 to DN 80 gate valves

5. Remove drive nut
6. Re-grease bearings (thrust race and bearing and bearing block bearing). If bonnet gasket is copper, anti gall high temp grease C-100 is recommended.

Assemble actuator

1. Re-install drive nut
2. Replace nut on DN 100 to DN 320 gate valves / Replace retaining ring on DN 40 to DN 80 gate valves
3. Tighten the set screw on the brass hex nut.
4. Replace the bearing block assembly by turning counter-clockwise.
5. Replace the bearing block screws (4 each) located above the bearing block.
6. Replace the knob by positioning it so the set screw matches the flat.
7. Tighten the set screw located on the side of the knob.
8. Replace the drive screw stop.
9. Replace the left-hand threaded screw located on the top of the actuator.

7.5 Replace bellows and shaft seals



- Always wear powder-free latex gloves when servicing the valve
- Be careful not to scratch o-ring groove
- Avoid twisting, stretching, or deforming the o-ring
- Avoid damaging the materials
- Heat gun may be required to melt any Loctite on jam nut threads

Use for manual gate valves with elastomer seal only. If your valve is a metal sealed gate valve (UHV), please send back to Pfeiffer Vacuum for servicing.

Required tools and materials

- 1 - 1/4" open ended wrench
- Allen wrench set: size 0.028" - 3/8"
- Calipers
- O-ring pick, plastic
- Retaining ring pick
- Needle-nose pliers
- Small standard screwdriver
- Powder-free latex gloves
- Actuator O-rings
- Grease for bellows O-ring: Apiezon L
- Vacuum grease
- IPA

Prerequisites

- Bonnet actuator carriage assembly removed
- Actuator knob and crank and bearing block removed

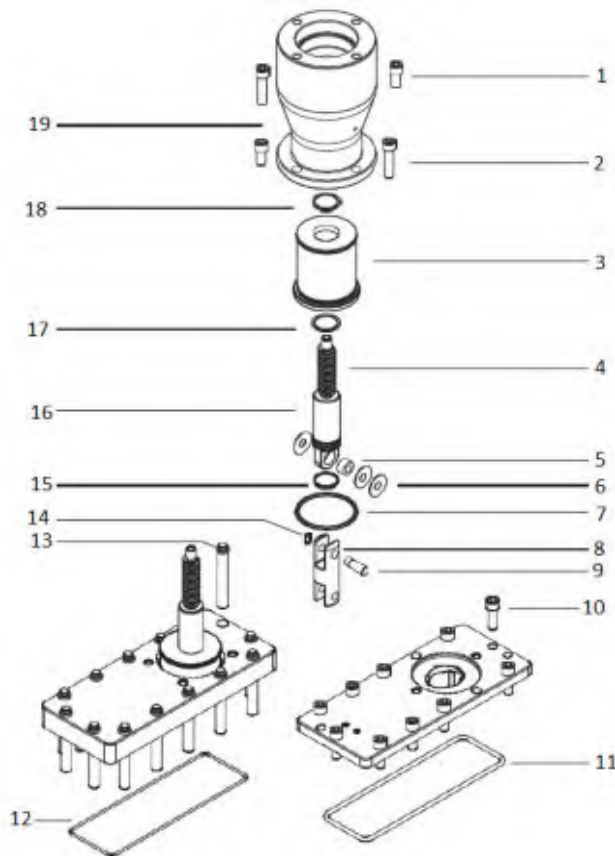

Fig. 7: Actuator and bonnet assembly

- | | | | |
|----|--|----|----------------|
| 1 | Screw, socket head, actuator housing | 11 | O-ring |
| 2 | Screw, socket head, actuator housing, long | 12 | Gasket |
| 3 | Bellows assembly, bellows end flange, bellows, bellows base flange | 13 | Screw |
| 4 | Acme thread | 14 | Retaining ring |
| 5 | Bearing | 15 | O-ring |
| 6 | Washer | 16 | Drive screw |
| 7 | Bellow flange O-ring | 17 | Retaining ring |
| 8 | Linkage | 18 | Retaining ring |
| 9 | Pin | | |
| 10 | Screw, socket head | | |

Disassemble bellows and shaft seals

1. Remove the remaining screws on the actuator housing.
2. Slide the actuator housing off the drive shaft.
3. Remove retaining ring from drive shaft, using a pick.
 - If a replacement is not available, use care to preserve the retaining ring. Otherwise, pull out using needle nose pliers and discard.
4. Remove bellows by pulling and twisting slightly and discard.
5. Remove O-ring in the bellows drive shaft area and discard.

Clean and assemble bellow and shaft seals

1. Clean drive shaft groove and bellows area with IPA.
2. Apply a thin coat of grease (Apiezon L) on the O-ring for the bellows base flange.
3. Install O-ring for the bellows base flange.
4. Replace bellows assembly on the drive shaft, pushing and twisting slightly to go over the O-ring.
5. Install retaining ring on the drive shaft, using a screw driver and a pick. Make sure it clicks into the groove next to the top of the bellows.

Assemble actuator

1. Apply a thin coat of vacuum grease to the drive shaft.
2. Install actuator housing on the bonnet plate (4 screws). Put long screws in before re-attaching actuator housing.
3. Install bearing block assembly onto left-handed ACME screw.
4. Install four bearing block screws.

5. Replace actuator knob and crank. Line up the set screw on the side of the knob with the flat on the drive nut.
6. Install the drive screw stop.
7. Install the washer and left-handed thread screw in top of drive shaft and tighten.
8. Test operation of valve before re-installing on the system.

7.6 Cleaning seal plate assembly, pins, and bearings

⚠ WARNING

Risk of injury due to incorrect installation

Dangerous situations may arise from unsafe or incorrect handling

- ▶ Do not put hands or any other body part or objects in the valve.



- Always wear powder-free latex gloves when servicing the valve
- Be careful not to scratch o-ring groove
- Avoid twisting, stretching, or deforming the o-ring
- Avoid damaging the materials
- Heat gun may be required to melt any Loctite on jam nut threads

DN 100 and up sizes only

Required tools and materials

- Allen wrench set: size 0.028" - 3/8"
- Arbor press
- Punch
- Hammer
- Wrenches, box or open
- Retaining ring pliers
- Calipers
- Vacuum grease: Castrol Braycote 296
- IPA
- Powder-free latex gloves
- Replacement pins, bearings, washers, and retaining rings; optional gate spring

Prerequisites

- Vacuum system on both sides of the valve vented to atmosphere
- Valve actuated to GATE OPEN position
- Bonnet actuator carriage assembly removed

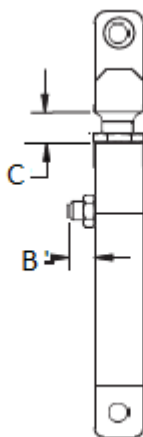

Fig. 8: Lowerlink assembly adjustment

Disassemble gate from strongback

1. Using a punch and hammer, remove the pin that holds the upper linkage to the lower linkage-upper linkage of the strongback.
2. Inspect the pin assembly and place the punch on the end with the retaining ring.
 - If the pin does not move, turn the assembly over and try from the other side.
3. Discard all pins, washers, and retaining rings and replace with all new parts.
 - There should be three washers and a retaining ring recovered along with the pin.
 - Caution: Be careful not to bend the upper linkage; the use of a block for support is recommended.
4. Separate the bonnet upper linkage assembly from the carriage assembly.
5. Measure and record the distance between the gate lower linkage and the upper linkage-lower linkage, dimension C.
6. For DN 160 and DN 200 valves, measure the overcenter adjustment, dimension B, and record it.
7. Remove gate spring by removing one set screw.
 - Now the gate can be raised slightly from the strongback
8. Remove four screws that mount the gate to the strongback. They are accessible under the gate, two each end, top and bottom
9. Separate the gate from the strongback by lifting off the gate from the strongback as if opening a book with the bottom of the assembly as the spine of the book.
10. Remove set screws, links, washers, pins, and carriage bars and discard all used parts, except carriage bars.
11. Using a punch and hammer, remove pins from wheels.
 - Before punching, inspect the pin assembly and place the punch on the end with the retaining ring.
 - If the pin does not move, try from the other side.
12. Using an arbor press, remove the bearings from the links and wheels and discard expendable parts.
13. Clean all reusable parts such as the gate, strongback, links, carriage bars, and gate spring with IPA.

Assemble gate to strongback

1. Press the new bearings in using an arbor press.
 - For FKM bonnet sealing valves, ensure that the bearings are properly lubricated with vacuum grease.
 - For copper sealed bonnet valves, run bearings dry.
2. Verify that all bearings spin freely.
3. Install the washers, pins, and retaining rings into strongback using the recommended technique.
 - Slide long side of pin through hole first (the side without the groove)
 - Install retaining ring close to the end of the pin, not in the groove
 - Add one washer
 - Add the wheel, then one more washer
 - Push pin in until the retaining ring snaps into its groove
4. Verify that all wheels spin freely.
5. Set strongback aside for later assembly.
6. Install links, washers, and pins into gate slots. Use a small amount of vacuum grease on washers to make them stick to the links during assembly.
7. Adjust pins to correspond to strongback pin pockets.
 - Align the pins so they will be in the center of each slot when the gate lies on the strongback.
8. Install gate to strongback and verify that all pins fit into strongback pockets.
9. Install four new set screws under the gate which were removed earlier. Watch to see that the gate does not rise up when the set screws are tightened.
10. Verify that the gate is flush with the strongback in the down position and moves freely up and down.
11. Install gate spring.
 - This may require pressure to compress the spring.
12. Install and tighten set screw
13. Re-attach upper linkage to strongback lower linkage-upper linkage
 - Slide long side of pin through hole first (the side without the groove)
 - Install retaining ring close to the end of the pin, not in the groove
 - Add one washer

- Add the upper link, then the other two washers
 - Push pin in until the retaining ring snaps into its groove
14. Verify that the link moves freely.
 15. Verify dimensions B and C that were recorded earlier and adjust as necessary.
 - The bonnet actuator carriage assembly can now be reinstalled into the valve body.

Assemble valve

1. Replace the complete assembly into the valve body.
2. Tighten the bolts.
3. Test the valve operation to ensure proper functionality.
4. If necessary, refer to the valve adjust procedure to fine tune the valve.

7.7 Valve adjustment



- Always wear powder-free latex gloves when servicing the valve
- Be careful not to scratch o-ring groove
- Avoid twisting, stretching, or deforming the o-ring
- Avoid damaging the materials
- Heat gun may be required to melt any Loctite on jam nut threads

Compression, DN 40 and larger sizes

Required tools and materials

- Allen wrench set: size 0.028" - 3/8"
- Wrench set, box or open
- Calipers
- Replacement gasket or O-ring
- Powder-free latex gloves

Prerequisites

- Valve removed from the system or system vented to atmosphere
- Valve in GATE OPEN position
- Bonnet actuator carriage assembly removed

Compression Adjustment Procedure

1. Adjust linkage per adjustment chart. Loosen nut and re-tighten
2. Replace bonnet bellows assembly onto body, using two bolts, one on opposite ends of bonnet plate.
3. When gate compression is correct, remove actuator bonnet carriage making sure that nut is tight.
 - Note: When valve is adjusted properly, you will hear and feel a small click as the valve locks into place.

Valve size	Dimension C compression adjust
DN 40	5.334 mm
DN 50	9.144 mm
DN 63	4.826 mm
DN 80	9.906 mm
DN 100	10.668 mm
DN 160	8.890 mm
DN 200	6.604 mm
DN 250	12.700 mm
DN 260	16.510 mm
DN 300	13.208 mm
DN 350	11.176 mm
DN 400	18.542 mm
DN 450	11.176 mm

Valve size	Dimension C compression adjust
DN 500	13.970 mm
DN 800	24.765 mm

Tbl. 8: Valve adjustment chart

8 Decommissioning

Dismounting the valve

1. Vent system to atmosphere
2. Close the valve
3. Carefully loosen the bolts around the flange
4. Dismount the valve from the system

9 Recycling and disposal

WARNING

Health hazard through poisoning from toxic contaminated components or devices

Toxic process media result in contamination of devices or parts of them. During maintenance work, there is a risk to health from contact with these poisonous substances. Illegal disposal of toxic substances causes environmental damage.

- ▶ Take suitable safety precautions and prevent health hazards or environmental pollution by toxic process media.
- ▶ Decontaminate affected parts before carrying out maintenance work.
- ▶ Wear protective equipment.



Environmental protection

You **must** dispose of the product and its components in accordance with all applicable regulations for protecting people, the environment and nature.

- Help to reduce the wastage of natural resources.
- Prevent contamination.

9.1 General disposal information

Pfeiffer Vacuum products contain materials that you must recycle.

- ▶ Dispose of our products according to the following:
 - Iron
 - Aluminium
 - Copper
 - Synthetic
 - Electronic components
 - Oil and fat, solvent-free
- ▶ Observe the special precautionary measures when disposing of:
 - Fluoroelastomers (FKM)
 - Potentially contaminated components that come into contact with media

10 Malfunctions

Problem	Possible causes	Remedy
Leak at gate	Dirty or damaged gate seal	<ul style="list-style-type: none"> • Replace the gate seal • Contact Pfeiffer Vacuum Service
Leak at body	Dirty or damaged bonnet gasket	<ul style="list-style-type: none"> • Check for a leak using a leak detector on the actuator • Replace the bonnet seal • Contact Pfeiffer Vacuum Service
Valve opening or closing on its own	Loose tension in the manual bearing block	Tighten the tension in the manual bearing block assembly
Gate open/close is stuck	<ul style="list-style-type: none"> • Wheels and bearings in the gate/carriage assembly have seized • Flanges have been over-tightened and are compressing the body causing the gate to seize • Bolts used in the flanges are too long and have dented the inside of the body 	<ul style="list-style-type: none"> • Replace the wheels and bearings in the gate/carriage assembly • Contact Pfeiffer Vacuum Service

Tbl. 9: Troubleshooting the valve

11 Service solutions by Pfeiffer Vacuum

We offer first-class service

High vacuum component service life, in combination with low downtime, are clear expectations that you place on us. We meet your needs with efficient products and outstanding service.

We are always focused on perfecting our core competence – servicing of vacuum components. Once you have purchased a product from Pfeiffer Vacuum, our service is far from over. This is often exactly where service begins. Obviously, in proven Pfeiffer Vacuum quality.

Our professional sales and service employees are available to provide you with reliable assistance, worldwide. Pfeiffer Vacuum offers an entire range of services, from [original replacement parts](#) to [service contracts](#).

Make use of Pfeiffer Vacuum service

Whether preventive, on-site service carried out by our field service, fast replacement with mint condition replacement products, or repair carried out in a [Service Center](#) near you – you have various options for maintaining your equipment availability. You can find more detailed information and addresses on our homepage, in the [Pfeiffer Vacuum Service](#) section.

You can obtain advice on the optimal solution for you, from your [Pfeiffer Vacuum representative](#).

For fast and smooth service process handling, we recommend the following:



1. Download the up-to-date form templates.
 - [Explanations of service requests](#)
 - [Service requests](#)
 - [Contamination declaration](#)



- a) Remove and store all accessories (all external parts, such as valves, protective screens, etc.).
 - b) If necessary, drain operating fluid/lubricant.
 - c) If necessary, drain coolant.
2. Complete the service request and contamination declaration.



3. Send the forms by email, fax, or post to your local [Service Center](#).

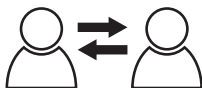

4. You will receive an acknowledgment from Pfeiffer Vacuum.

PFEIFFER VACUUM

Submission of contaminated products

No microbiological, explosive, or radiologically contaminated products will be accepted. Where products are contaminated, or the contamination declaration is missing, Pfeiffer Vacuum will contact you before starting service work. Depending on the product and degree of pollution, **additional decontamination costs** may be incurred.

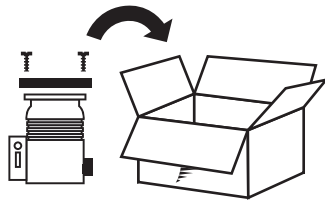

5. Prepare the product for transport in accordance with the provisions in the contamination declaration.
 - a) Neutralize the product with nitrogen or dry air.
 - b) Seal all openings with blind flanges, so that they are airtight.
 - c) Shrink-wrap the product in suitable protective foil.
 - d) Package the product in suitable, stable transport containers only.
 - e) Maintain applicable transport conditions.

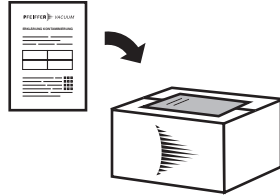

6. Attach the contamination declaration to the **outside** of the packaging.

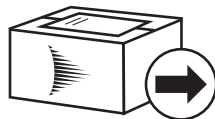

7. Now send your product to your local Service Center.

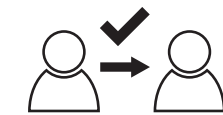

8. You will receive an acknowledgment/quotation, from Pfeiffer Vacuum.

PFEIFFER VACUUM

Our sales and delivery conditions and repair and maintenance conditions for vacuum devices and components apply to all service orders.

12 Spare parts - Gate valve

For size not shown on the below tables, please contact Pfeiffer Vacuum for more information on the recommended spare parts.

Size	Elastomer or metal sealed gate valve	Part number
DN 40 - DN 80	Elastomer (GV or GVP)	KBB15S - 96
DN 100 - DN 200	Elastomer (GV or GVP)	KBB4-85
DN 250 - DN 320	Elastomer (GV or GVP)	KBB10-12S-96
DN 40	Metal seal (GVM or GVMP)	KBB15M-96
DN 63	Metal seal (GVM or GVMP)	KBB25M -96
DN 100	Metal seal (GVM or GVMP)	KBB40M -96
DN 160	Metal seal (GVM or GVMP)	KBB60M-96
DN 200	Metal seal (GVM or GVMP)	KB80M-96

Tbl. 10: Overview of the bellow kits available for the gate valves

Size	Elastomer or metal sealed gate valve	Part number
DN 40	Elastomer (GV or GVP)	KSB15S
DN 63	Elastomer (GV or GVP)	KSB25S
DN 100	Elastomer (GV or GVP)	KSB40S
DN 160	Elastomer (GV or GVP)	KSB60S
DN 200	Elastomer (GV or GVP)	KSB80S
DN 250	Elastomer (GV or GVP)	KSB100S
DN 320	Elastomer (GV or GVP)	KSB120S
DN 40	Metal seal (GVM or GVMP)	KSB-15SM
DN 63	Metal seal (GVM or GVMP)	KSB-25M
DN 100	Metal seal (GVM or GVMP)	KSB-40M
DN 160	Metal seal (GVM or GVMP)	KSB-60M
DN 200	Metal seal (GVM or GVMP)	KSB-80M
DN 250	Metal seal (GVM or GVMP)	KSB-100M
DN 320	Metal seal (GVM or GVMP)	KSB-120SM

Tbl. 11: Overview of the seal kits available for the gate valves

13 Technical data and dimensions

13.1 General

	mbar	bar	Pa	hPa	kPa	Torr mm Hg
mbar	1	$1 \cdot 10^{-3}$	100	1	0.1	0.75
bar	1000	1	$1 \cdot 10^5$	1000	100	750
Pa	0.01	$1 \cdot 10^{-5}$	1	0.01	$1 \cdot 10^{-3}$	$7.5 \cdot 10^{-3}$
hPa	1	$1 \cdot 10^{-3}$	100	1	0.1	0.75
kPa	10	0.01	1000	10	1	7.5
Torr mm Hg	1.33	$1.33 \cdot 10^{-3}$	133.32	1.33	0.133	1

$$1 \text{ Pa} = 1 \text{ N/m}^2$$

Tbl. 12: Conversion table: Pressure units

	mbar l/s	Pa m ³ /s	sccm	Torr l/s	atm cm ³ /s
mbar l/s	1	0.1	59.2	0.75	0.987
Pa m ³ /s	10	1	592	7.5	9.87
sccm	$1.69 \cdot 10^{-2}$	$1.69 \cdot 10^{-3}$	1	$1.27 \cdot 10^{-2}$	$1.67 \cdot 10^{-2}$
Torr l/s	1.33	0.133	78.9	1	1.32
atm cm ³ /s	1.01	0.101	59.8	0.76	1

Tbl. 13: Conversion table: Units for gas throughput

13.2 Technical data and product dimensions

- Please refer to the Pfeiffer Vacuum website for specific valve size and configuration data sheets and dimensions.
- If your valve is not listed on the Pfeiffer Vacuum website, please contact Pfeiffer Vacuum Service for more information.

VACUUM SOLUTIONS FROM A SINGLE SOURCE

Pfeiffer Vacuum stands for innovative and custom vacuum solutions worldwide, technological perfection, competent advice and reliable service.

COMPLETE RANGE OF PRODUCTS

From a single component to complex systems:

We are the only supplier of vacuum technology that provides a complete product portfolio.

COMPETENCE IN THEORY AND PRACTICE

Benefit from our know-how and our portfolio of training opportunities!

We support you with your plant layout and provide first-class on-site service worldwide.

ed. A - Date 2303 - P/N:NV40210EN



Are you looking for a
perfect vacuum solution?
Please contact us

Pfeiffer Vacuum GmbH
Headquarters • Germany
T +49 6441 802-0
info@pfeiffer-vacuum.de

www.pfeiffer-vacuum.com

PFEIFFER  **VACUUM**